

**7000 N·m VERTICAL POWER TOOL
TEST FIXTURE**



CONTENTS

Part Numbers Covered by this Manual	2
Introduction	2
Safety	2
Fitting Instructions	3
Securing the Fixture to a Solid Surface	3
Fitting the Transducer	3
Operating Instructions	4
Specifications	4
Maintenance	4
Service / Repair	4

PART NUMBERS COVERED BY THIS MANUAL

Part Number	To Fit Transducers	Drive Square	Maximum Torque
50801 & 50804	50703.LOG	1 1/2"	2500 N·m
	50704.LOG	1 1/2"	2500 lbf·ft
	50599.LOG	1 1/2"	5000 N·m
	50630.LOG	1 1/2"	5000 lbf·ft
	50669.LOG	1 1/2"	7000 N·m

INTRODUCTION

This manual covers the setup and use of the Norbar vertical power tool test fixture. This Calibration fixture is designed to be used with the correct Norbar calibrated static transducer to test inline power tools using the standard Norbar adaptor plates.

SAFETY

IMPORTANT: DO NOT OPERATE THE SYSTEM BEFORE READING THESE INSTRUCTIONS. FAILURE TO DO SO MAY RESULT IN PERSONAL INJURY OR DAMAGE TO THE TOOL UNDER TEST.

Isolate the tool from all energy sources before changing or adjusting the drive square or socket.



There is a risk of crushing between the reaction bar and work piece.

Keep hands away from reaction bar.

Keep hands away from tool output.

Keep loose clothing, hair, etc. from being caught in any rotating part of the tool.

Use only sockets and adaptors which are in good condition and are intended for use with power tools.

Read operating instructions for power tools.

Read operating instructions for transducer and measurement instrument.

FITTING INSTRUCTIONS

Securing the Fixture to a Solid Surface

The fixture should be securely fastened to a solid bench of sufficient strength to withstand the weight of the fixture. Provision should be made to machine 3 holes into the bench to accommodate the supplied M8 x 50 long cap head screws, using the fixture as a guide to correctly position the holes. The M8 screws should be tightened against M8 nuts and washers (not supplied).

Fitting the Transducer

Once the fixture has been secured the static transducer needs to be fitted as follows:

1. Remove the rundown housing assembly by undoing the thumb screws and retention washers from the locating reaction posts. Lift using the lifting eyes.
2. Remove the 6 shoulder screws and lift the reaction plate off the test fixture base.
3. Slide the male square of the transducer into the female square of the test fixture base. Ensuring that the transducer is in the correct orientation to align the electrical connector plug with the side hole, as shown below.
4. Reposition the reaction plate on top of the test fixture base and secure in place with the shoulder screws. Tighten screws to 27 N·m.
5. Realign the rundown housing assembly with the reaction plate, ensuring that the male square of the rundown is located within the female square of the transducer.
6. Finally, secure the rundown housing assembly in place by sliding the locating reaction posts back into position and locking them with the thumb screws and retention washers.

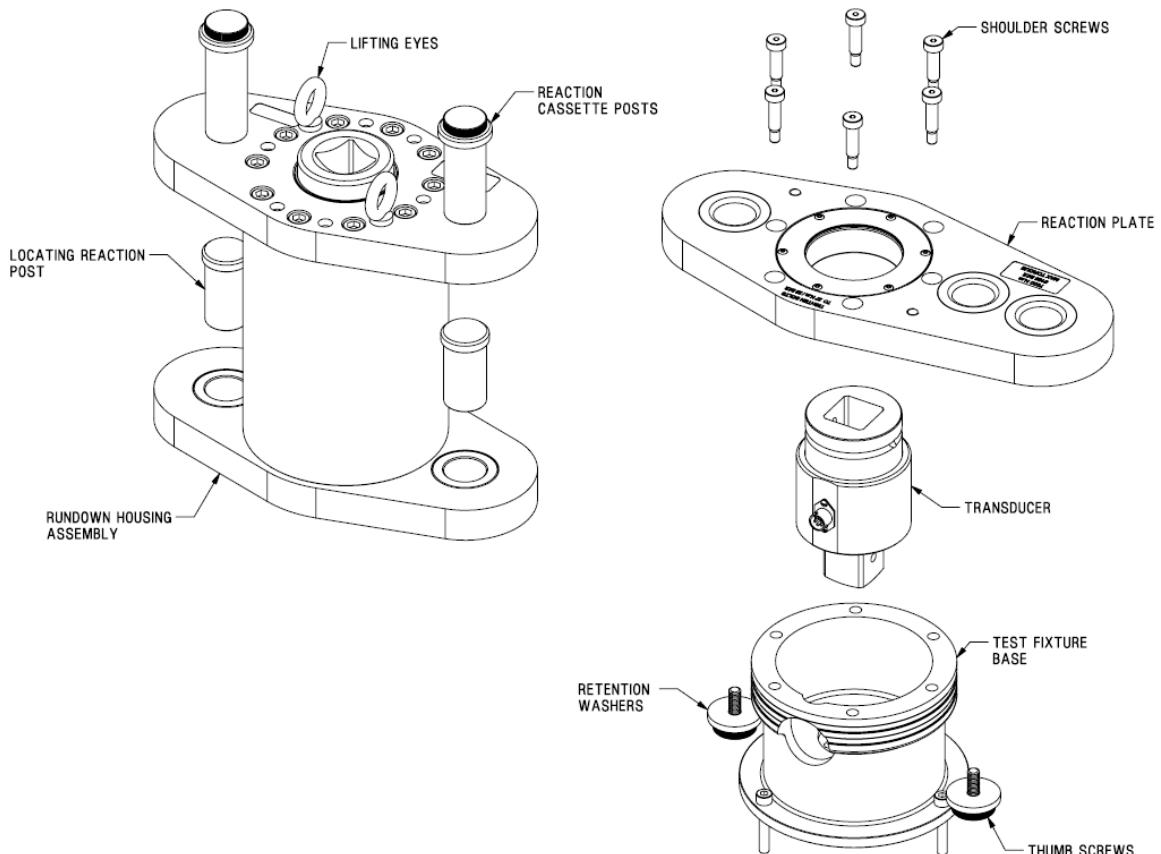

OPERATING INSTRUCTIONS

The fixture should be securely fastened to a solid bench of sufficient strength to withstand the weight of the fixture. Never use with a larger capacity tool than the fixture is designed to operate at, as stated on the cassette reaction plate.

Remove the standard reaction from the power tool that is under testing. Locate the appropriate reaction plate and adaptor socket to suit the power tool. Attach the reaction plate to the front of the tool and position the correct adaptor socket on to the fixture. Remove the thumb screws and retention washers from the reaction cassette posts. Slide the reaction plate with tool attached over the two reaction cassette posts and reattach the retention washers and thumb screws. Free run the tool until it is possible to locate the square into the adaptor socket. Keep all body parts away from reaction plates when operating.

Once the power tool is set in the fixture, operate the tool to the required torque and take the reading from the display device.



WARNING: KEEP HANDS CLEAR OF THE REACTION PLATE.



SPECIFICATIONS

Part Number	Dimensions	Weight (Excluding Transducer)	Maximum Torque
50801	H 534mm x L 415mm x W 190mm	160 Kg	7000 N·m
50804	H 534mm x L 415mm x W 190mm	79 Kg	7000 N·m

MAINTENANCE

Keep the tool in a clean condition to aid safety. Do not use abrasives or solvent based cleaners.

Service / Repair

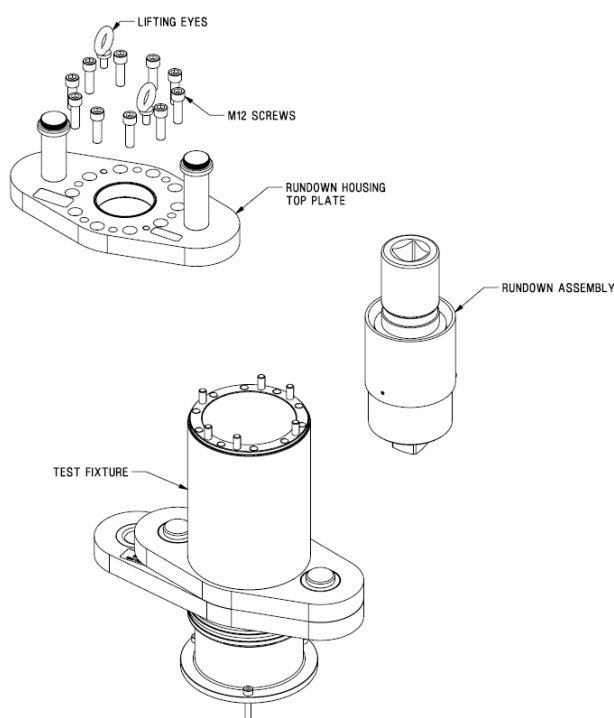

To access the rundown assembly for servicing or repair, follow the instructions below:

1. Remove the lifting eyes and M12 screws from the rundown housing top plate.
2. Use the lifting eye holes in the top plate with jacking screws to remove the plate from the test fixture.
3. Place the top plate to one side.
4. The rundown assembly can then be removed from the test fixture.

To service or repair the rundown assembly, complete the following steps:

1. Remove square drive, 50800.29, from the special UNC bolt, 50800.32.
2. Remove bolt with washers, spacers and nut attached from the sleeve.
3. 50800.32 can then be disengaged from 50800.33, releasing the spacers and washers.
4. Service of required parts can then take place.
5. 50800.32 and 50800.33 are the items most prone to wear. It is recommended that these items be greased regularly with Rocol M204 G Graphite grease or Rocol Tufgear Universal. Replace components when worn as a set of nut and bolt together.

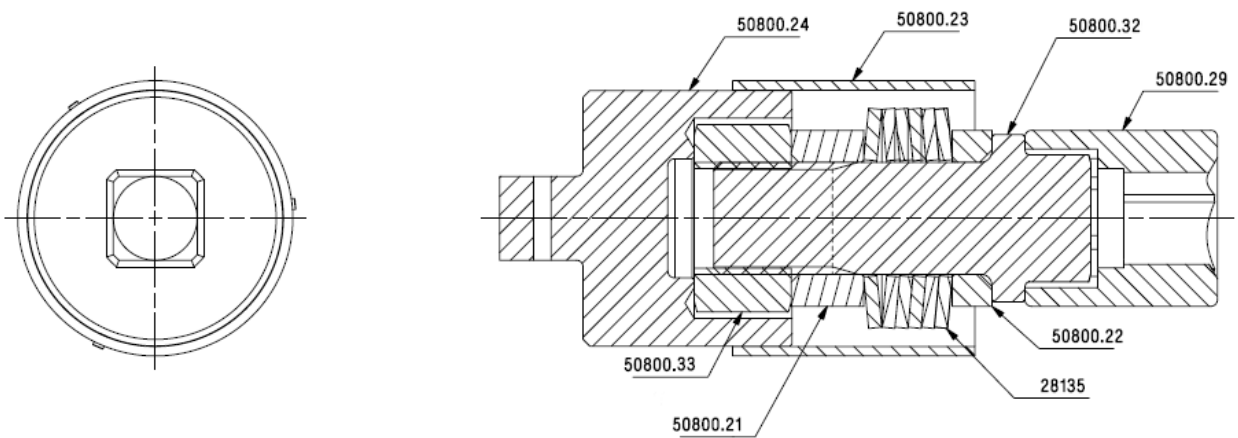

**NORBAR TORQUE TOOLS LTD**

Wildmere Road, Banbury,
Oxfordshire, OX16 3JU
UNITED KINGDOM
Tel + 44 (0)1295 270333
Email enquiry@norbar.com

**NORBAR TORQUE TOOLS PTE LTD**

194 Pandan Loop
#07-20 Pantech Business Hub
SINGAPORE 128383
Tel + 65 6841 1371
Email enquires@norbar.sg

**NORBAR TORQUE TOOLS**

45–47 Raglan Avenue, Edwardstown,
SA 5039
AUSTRALIA
Tel + 61 (0)8 8292 9777
Email enquiry@norbar.com.au

**NORBAR TORQUE TOOLS (SHANGHAI) LTD**

7 / F, Building 91, No. 1122, Qinzhou North
Road, Xuhui District, Shanghai
CHINA 201103
Tel + 86 21 6145 0368
Email sales@norbar.com.cn

**NORBAR TORQUE TOOLS INC**

36400 Biltmore Place, Willoughby,
Ohio, 44094
USA
Tel + 1 866 667 2279
Email inquiry@norbar.us

**NORBAR TORQUE TOOLS INDIA PVT. LTD**

Plot No A-168, Khairne Industrial Area,
Thane Belapur Road, Mahape,
Navi Mumbai – 400 709
INDIA
Tel + 91 22 2778 8480
Email enquiry@norbar.in

www.norbar.com